

C700

Side-load Case Packer



The side-load case packer **C700** is suitable for packaging cartons, bundles, sachets, bags and flow-packs inside corrugated shipper (RSC). Controlled by servo motors, it features a balcony construction with full accessibility for easy cleaning, maintenance and timely operator interventions.

Products coming from the upstream machine to the in-feed belt are stacked bottom-up to the desired configuration and stacking pattern. Each RSC case is picked up from the magazine with a dual-arm system with suction cups that ensures positive case handling. After product loading, shippers are sealed by hot melt or PVC adhesive tape.

The C700 case packer fits any upstream CARIBA machine.

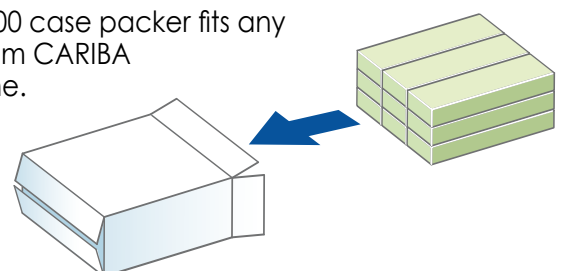

More than just packaging solutions

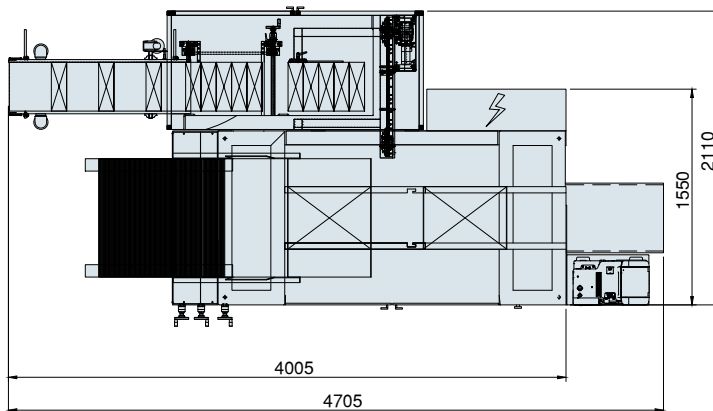
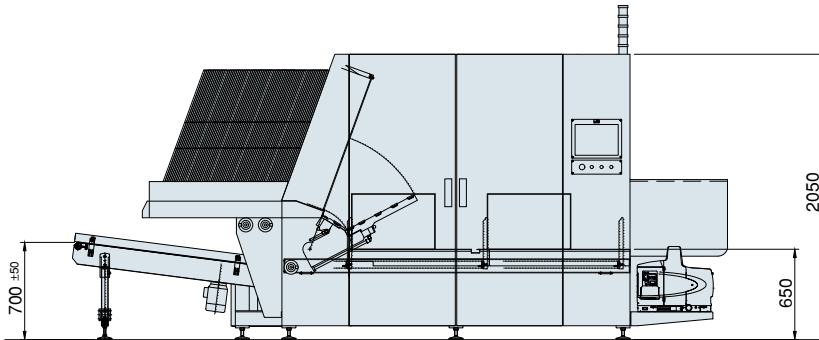
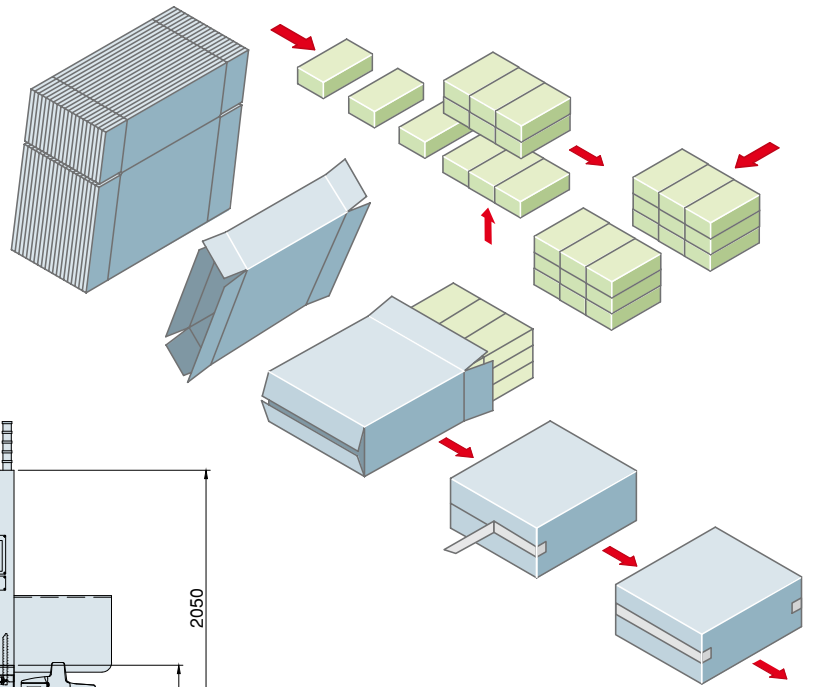

The machine can arrange:

- In-feed product orientation units with verification;
- Shipper flaps closures with hot-melt or PVC adhesive tape;
- Out-feed label print & apply stations and reject;
- Finished product turning on the side;
- Aggregation-ready devices with product verification before introduction inside the shipper;
- Remote connectivity.

Technical Data

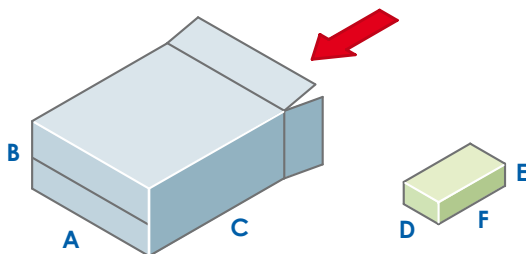

	A (mm)	B (mm)	C (mm)	D (mm)	E (mm)	F (mm)
C700	150 ÷ 600	130 ÷ 400	130 ÷ 400	15 ÷ 300	5 ÷ 85	70 ÷ 250

Mechanical output

Power supply

Installed power

Hot melt closure

PVC tape closure

Max. air consumption

Changeover time

Approx. weight

C700

12 cases/min
230÷400V - 50Hz

8 kW

4 kW

100 NI/min

15 min

1,900 kg