

# C730

Top-load Case Packer

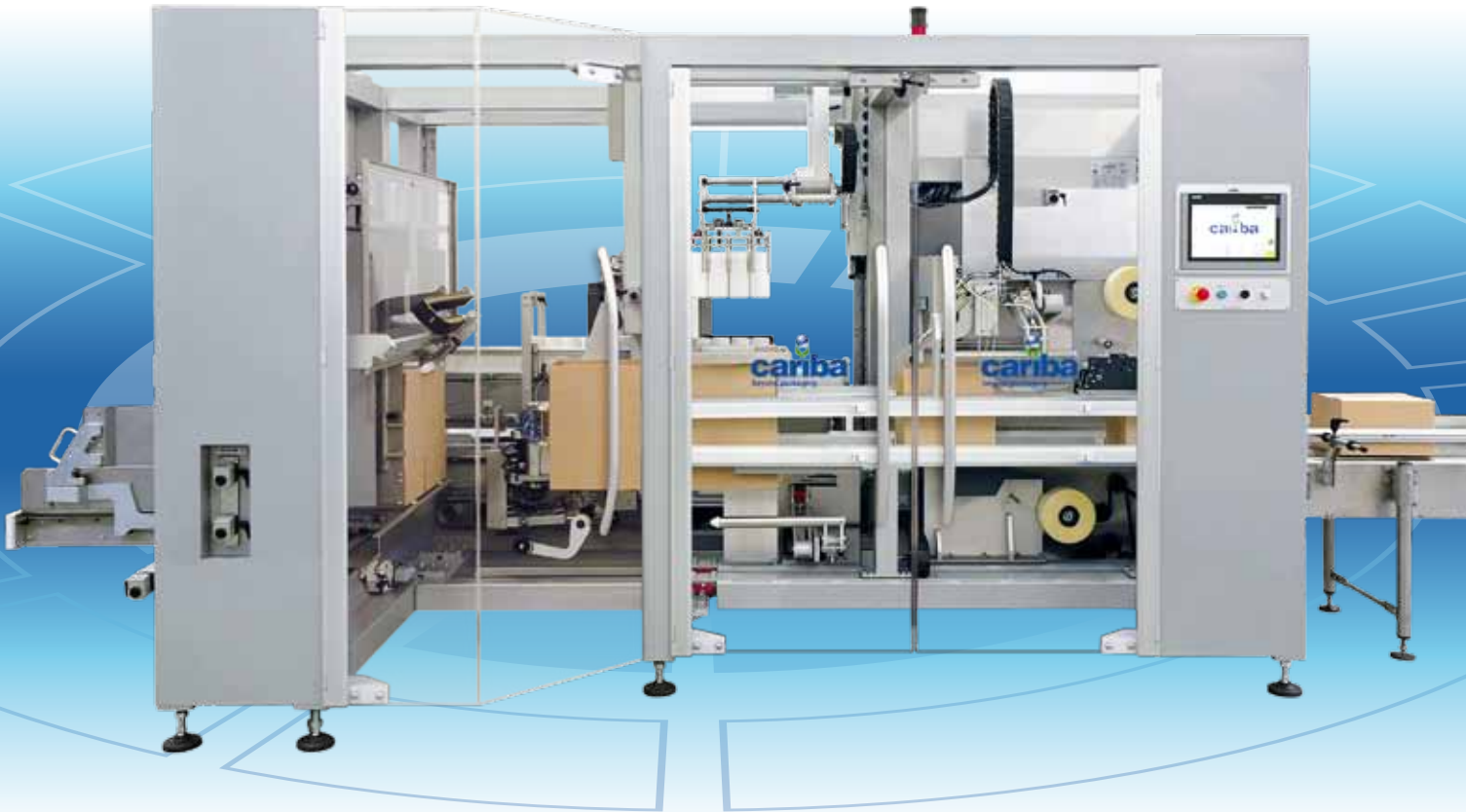

The top-load case packer **C730** is suitable for packaging of bottles, cartons, bundles, sachets, bags and flow-packs inside corrugated shipper (RSC). Controlled by servo motors, it features balcony construction with full accessibility inside the main frame for easy cleaning, maintenance and convenient operator interventions. Different infeed units are available to arrange the products before being vertically loaded by a robotic arm inside the shipper.

Each RSC case is picked from the magazine with a double arm system with suction cups that ensures positive case opening. After product loading, cases are sealed by hot melt or PVC adhesive tape. The **C730** case packer can be connected to any upstream CARIBA machine.

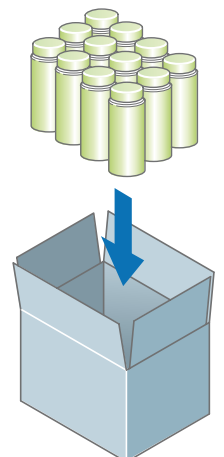

More than just packaging solutions

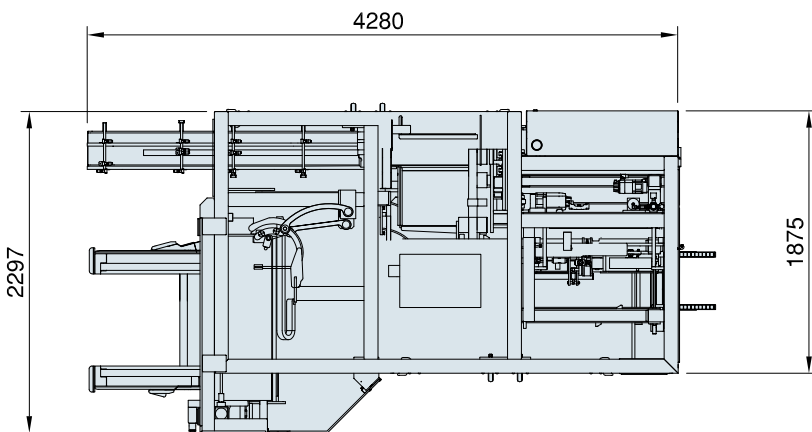
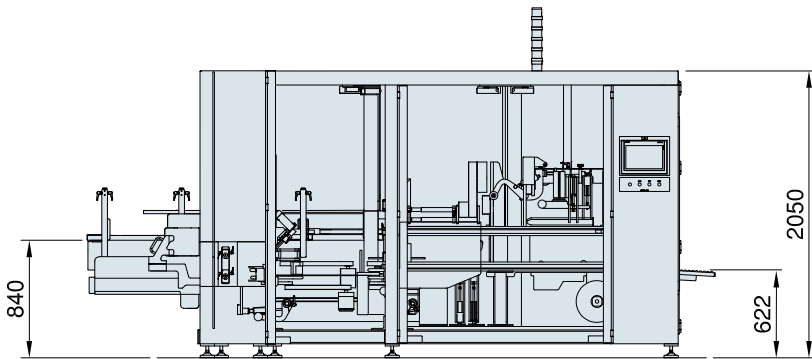
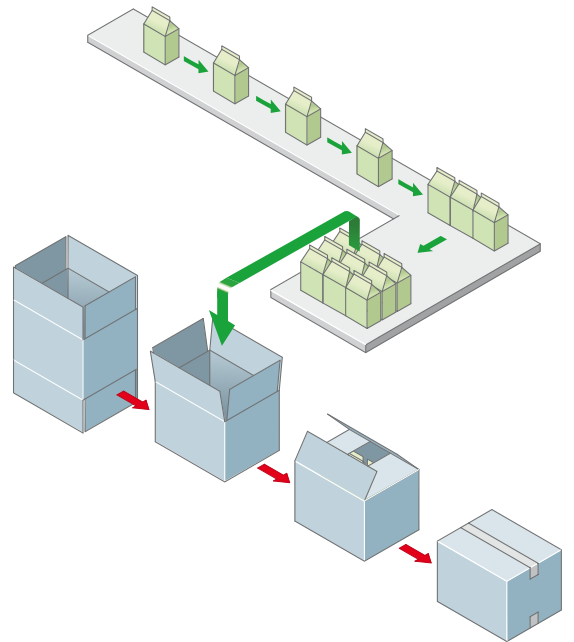
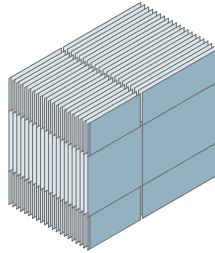

**The machine can be customized with:**

- Product orientation unit at in-feed with verification;
- Shipper flaps closure with hot-melt or PVC adhesive tape;
- Out-feed station with print & apply labeler and reject;
- Aggregation-ready with product verification before introduction inside the shipper;
- Remote connectivity.

## Technical Data

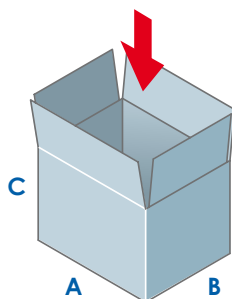

	A (mm)	B (mm)	C (mm)
<b>C730</b>	200 ÷ 600	150 ÷ 400	100 ÷ 350

	<b>C730</b>
<b>Mechanical output</b>	15 cases/min
<b>Power supply</b>	230-400V/50Hz
<b>Installed power</b>	
Hot-melt closure	12 kW
PVC tape closure	8 kW
<b>Max. air consumption</b>	300 NI/min
<b>Time to change size</b>	15 min
<b>Approx. weight</b>	2,700 kg